

Water Wizard 600

Continuous Flow Gas Water Heater

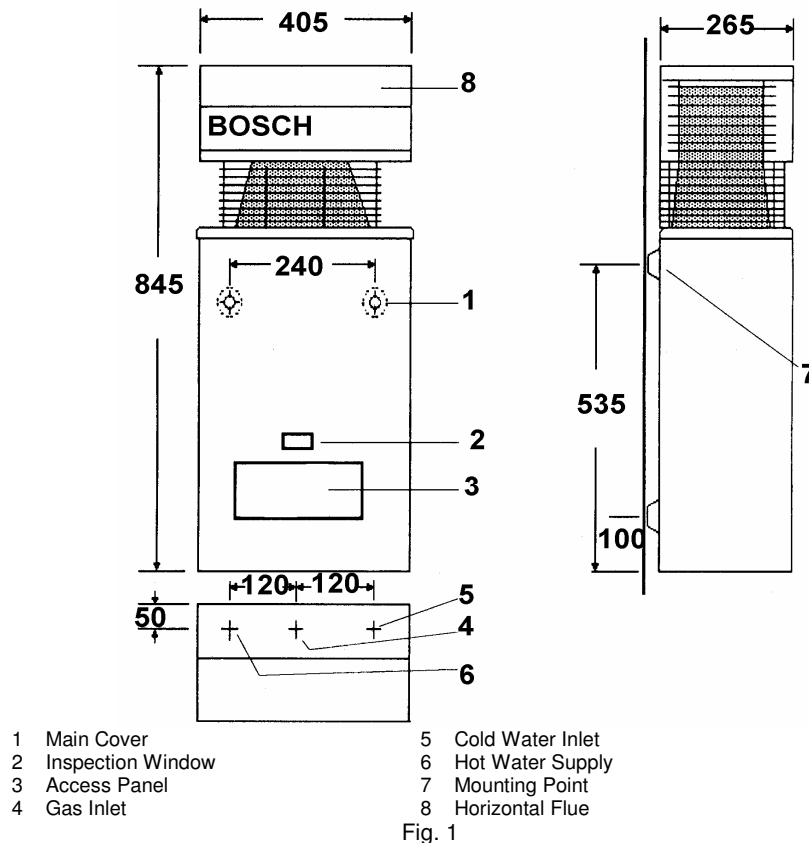

This appliance must be installed in accordance with the manufacturer's installation instructions, AG 601, NZ 5261, AS3500.4.2 and all Local Water, Building and Gas fitting regulations

**To be installed and serviced only by an authorised person
This appliance is not suitable for use as a pool heater**

The "authorised installing person" is responsible for :

1. Correct commissioning of this appliance.
2. Ensure unit performs to the specifications stated on the rating label.
- 3.. Demonstrate operation of unit to customer before leaving.
4. Hand these instructions to customer.

Failure to install this appliance in accordance with these installation instructions may void warranty

In the interest of continued product improvement, Bosch reserves the right to alter these specifications without notice

Installation

Install only on an external wall, as close as possible to the most frequently used hot tap. Use a heat shield (accessory item part number 9 708 061 400) if the unit is to be installed on a combustible surface. Allow minimum air gap of 10 mm between the flue and the heat shield, (refer figure 2).

Ensure that the flue terminal is clear of any combustible material, and avoid installation in a marine environment.

Install the appliance such that the base of the appliance is not more than 1.3 metres and not less than 0.5 meters from the ground, and allow for easy access to service heater.

Secure heater to wall using two 10g X 5/16 hex head wood screws (Ramset 610041 or similar). Locate head of screw in the key hole of the top mounting bracket.

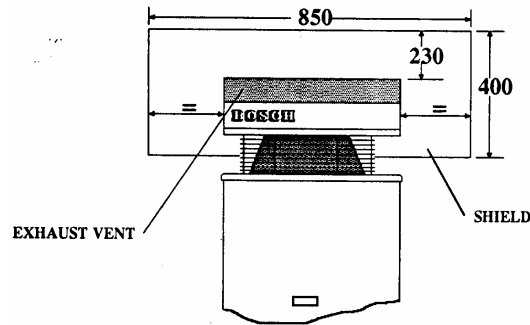

Fig. 2

Pipe Connections

Refer to Fig. 1 for locations

Hot and Cold water ½" male

Natural gas ¾" female

L.P. gas ½" male

A gas cock must be installed in the gas supply line with provision to disconnect the appliance. Install gate valve or full flow ball valve (fixed mechanism type) in cold water supply.

A non return valve must not be fitted. Example duo valve

We recommend that all hot water pipes be lagged if the runs are long or exposed, and water-proof lagging should be used on all external hot water pipes. If the water supply pressure exceeds 80% of the specified maximum, install a pressure limiting valve. If installing a pressure limiting valve fit a cold expansion valve between the limiting valve and the appliance. PLV = 500kPa Cold expansion = 700kPa

Refer to AG 601 and AS3500.1 for the relevant pipe size.

NOTE:Service calls for incorrect pipe sizing will **NOT** be covered under warranty.

Water Filter

If sludge or foreign matter is or may be present in the water supply, it is recommended that a suitable filter be incorporated in the water supply line to the heater. All pipes should be well flushed before connection is made.

A water filter/strainer is installed in the inlet of the brass water valve inside the appliance.

Water Temperature Adjustment

Located inside the water heater, immediately below the gas controls, is a water temperature selector knob.

To increase the water temperature (decrease water flow) turn the knob clockwise. To reduce water temperature (increase water flow) turn the knob anti clockwise.

Characteristic Data

Pilot orifice diameter (mm)	NG	0.30
	LPG	0.19
	TG	0.56
	TLP	0.56
Burner injector diameter (mm)	NG	1.20
	LPG	0.75
	TG	2.15
	TLP	2.15
Burner pressure (kPa)	NG	0.87
	LPG	2.60
	TG	0.40
	TLP	0.40

Water flow selector at left hand stop.

Maximum water flow	10 litres / minute
Temperature rise	25 °C
Minimum inlet pressure	NG 90 kPa (9.0 metres W.G.)
	LP 55 kPa (5.5 metres W.G.)

Water flow selector at right hand stop

Minimum water flow	4.5 litres / minute
Temperature rise	55 °C
Minimum inlet pressure	NG 30 kPa (3 metres W.G.)
	LP 10 kPa (1 metre W.G.)

Refer to rating label located on the bottom right hand corner of the back panel for additional data.

Freezing Weather

In areas where the atmospheric temperature may drop below 0 °C, the heater must be drained to prevent damage by expansion of freezing water. For appliances installed in locations where the temperature falls below 0 °C for brief periods, the installation of an EXOGEL expansion valve, (part number H 707 060 151), will minimise the possibility of damage to the appliance.

This water heater **MUST NOT** be installed in areas where the temperature remains below 0 °C for extended periods.

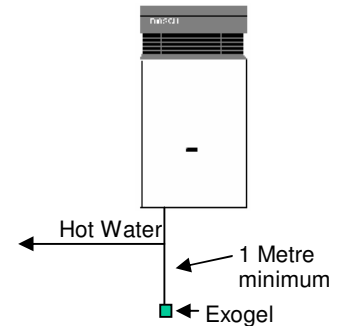

Conversion and Spare Parts

For spare parts or conversion of the heater to operate on a different gas that for which it was originally manufactured, please contact your local gas authority, authorised service agent or the manufacturer

Operating instructions

Open all hot water taps to expel any air prior to lighting
Remove front cover by loosening the two screws at the lower rear corners of the cabinet.
Check that gas and water valves are open, operate as indicated in Fig. 3
Refit front cover and tighten screws

Fig. 3

OPERATING INSTRUCTIONS

STARTING

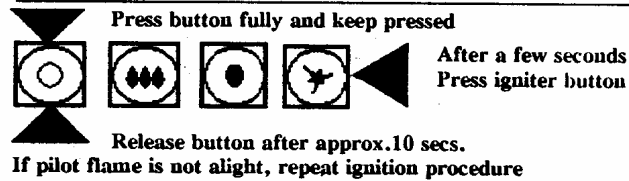

OPERATION

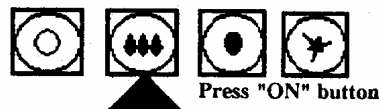

TEMPERATURE CONTROL

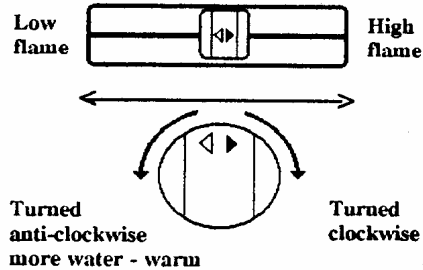

IMPORTANT

TURN HOT WATER TAP ON FULLY WHEN USING

SHUTTING OFF

(If no hot water is to be drawn for a longer period of time)

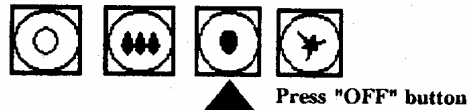

Warning - If the pilot light is extinguished, wait 5 minutes before attempting to relight the appliance. If the appliance does not operate, burns with yellow flame, leaks water or a gas smell is evident, turn off and contact the local gas authority, the manufacturer or an authorised service person.
When attempting to light the appliance ensure that all hot water taps are turned off.

Commissioning

Natural Gas Inlet Pressure Adjustment

With the gas supply turned off, remove sealing screw from inlet pressure test point located on the right hand side of the gas section refer Fig. 4 pos.A, attach manometer. Turn on gas and light heater. Open hot water tap fully and adjust gas pressure regulator to 0.95 - 1.05 kPa . Turn off gas and water, remove manometer, replace sealing screw and test for escape.

Natural Gas Burner Pressure Adjustment

Turn off gas supply, loosen captive screw in burner pressure test point, left hand side of burner manifold refer Fig.5 Pos A, attach manometer turn on hot water tap fully and check pressure.

Adjust pressure by turning the knurled wheel clockwise to increase gas pressure, anti clockwise to decrease. refer Fig 4 Pos.E

LP Gas Pressure Adjustment

No adjustment is provided at the appliance for inlet pressure, check cylinder regulator and pipe sizing.

Adjust burner pressure same as for Natural Gas.

For LP Gas we recommend the installation of two or more supply cylinders and an auto change over pressure regulator

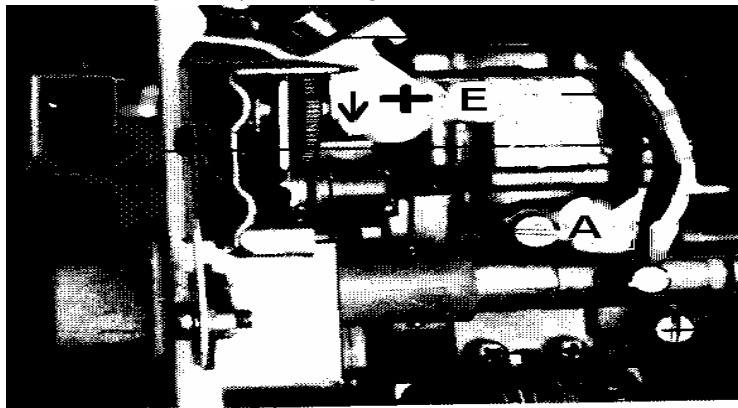

Fig. 4



Fig 5

Maintenance

We recommend that the appliance be inspected and cleaned by an authorised person periodically, depending upon the frequency and duration of its operation, but never less than once a year.

Fault Finding.

Problem	Possible Cause	Solution
Appliance does not light	No gas supply Blocked pilot	Connect to supply Replace pilot injector
Pilot lights but no main burner	Split/Distorted diaphragm	Replace
Smell of gas	Luminous flame Loose gas connection	Clean burner Locate leak with soap solution
Yellow flame	Burner venturi blocked	Clean with venturi brush
Water leak on top of water valve lid	Damaged O ring Excessive pressure Frost damage	Replace O ring, grease with Unisilkon L641# 8709918413 Check water isolating valve. (Must be gate valve or similar) Drain appliance or fit Exogel expansion valve # H707060151
Low burner flame, water does not heat up.	Low inlet gas pressure Low burner pressure	Check supply regulator and pipe size Check appliance regulator Check thermostat bellows Check thermostat insert
Low water temperature	Water flow rate set too high Low gas pressure Thermostat faulty/out of adjustment	Set flow rate Check pressure Replace/Adjust thermostat
Low water flow	Low water pressure Blocked water valve Blocked heat exchanger Blocked shower rose or tap aerator	Check and adjust Clean filter Descale Clean
Shower goes hot & cold	Low flow water saver shower rose	Replace with less restrictive rose. Check operation at other tap
Operates only at high water flow	Relief valve spring corroded Installed incorrectly, cold supply to hot outlet	Replace valve Correct installation
Cuts off when operating	Thermostat faulty/out of adjustment Wrong thermostat insert	Replace/Adjust thermostat Fit correct part
Operates only with slow light valve loose	Faulty diaphragm Blocked passage between slow light & venturi Faulty slow light valve	Replace Clean Clean/Replace

Warranty Details

Your Bosch Hot Water Unit is guaranteed as follows:

For appliances used in domestic applications, ie. normal hot water drawn from household outlets, the warranty period is Two (2) years parts and labour. Additionally, the heat exchanger is covered for a period of ten (10) years (parts only).

For appliances used in commercial applications the warranty period is Twelve(12) months parts and labour including the heat exchanger.

The warranty period commences from the purchase date. Claims for warranty will only be accepted upon suitable proof of purchase submitted to Robert Bosch (Australia) Pty. Ltd. or an approved Bosch Service Agent authorised to carry out warranty repairs.

PURCHASER'S STATUTORY RIGHTS

The warranty terms set out below do not exclude any conditions or warranties which may be mandatory implied by law, and your attention is drawn to the provisions of the Trade Practices Act, 1974, and State legislation which confers certain rights upon consumers. The ROBERT BOSCH (AUSTRALIA) PTY. LTD. Warranty supplements these.

EXTRACT OF TERMS OF DELIVERY AND SALE:

Warranty of products marketed by Robert Bosch (Australia) Pty. Ltd. herein referred to as RBAU.

- a) RBAU warrants products marketed by it as free from faults and defects and having the specified qualities according to the respective state of technology. Notwithstanding that the products may have been sold by description or sample the products shall be accepted by the Buyer even though alterations in design or construction have been generally introduced between the date of contract and the delivery of the products.
- b) The warranty shall be limited to the replacement or repair at the option of RBAU of any defective products and of such parts of RBAU's products as have been damaged in consequence of the defect despite proper treatment. Parts replaced will not be returned.
- c)
 - i) Repairs and maintenance shall not extend the warranty period of the appliance.
 - ii) If the product is located outside of the service agent's area, the consumer shall be responsible for the service agent's travelling costs, and if necessary the expenses of freight, packing and charges of a similar nature.

Without limiting the generality of these terms of delivery this warranty shall not apply to products sold in the following cases :--

- i) if the products sold are repaired or altered by any third party without RBAU's consent.
- ii) where parts not manufactured or sold by RBAU are used in and replacement or repair.
- iii) if products are not used with proper care and for the purpose for which they are sold and in accordance with any specified instruction for use.
- iv) if changes occur in the condition or operational qualities of the products due to incorrect storage or mounting or due to climatic or other influences.
- v) in respect of faulty construction or defects due to the use of unsuitable materials if such method of construction or use of material has been specified by the Buyer.
- vi) in respect of surface coating and glass damage.
- vii) in respect of the replacement of parts when such replacements are part of the normal maintenance, service or normal wear and tear.

No servant or authorised service agent has authority to add to or alter the terms of this warranty.

PLEASE NOTE:- If a service call is requested and it is found that it is not a manufacturing fault, you may be charged for the call even during the warranty period.

ROBERT BOSCH (AUSTRALIA) PTY. LTD. (Incorporated in Victoria) Phone 1300 307 037
1555 Centre Road, Clayton VICTORIA 3169