

Comprehensive range covering
Passenger, Commercial,
Heavy Duty, Stationary Engines,
Marine & Common Spare Parts

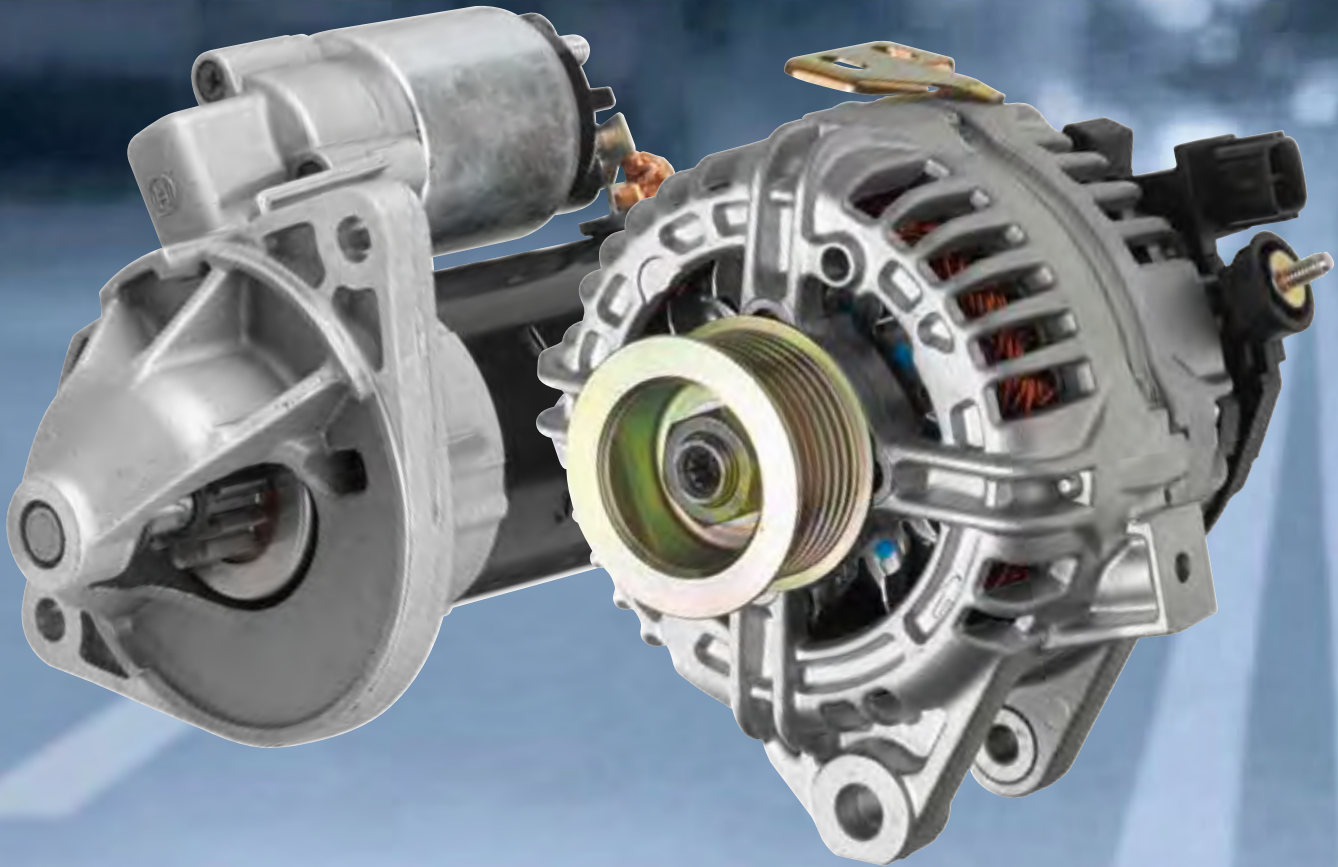

**Starter Motors and Alternators
For Australia & New Zealand**

2010 | 2011



BOSCH

Invented for Life



From the very beginning, Bosch's history has been characterised by a drive for innovation and social commitment. Environmental and social responsibilities are core values at Bosch. Our slogan "Invented for life" conveys the ambitious standards we have set ourselves and the values that we have long stood for. "Invented for life" stands for reliable technology designed and built to last. At the same time it embodies innovations and technology that contribute to the conservation of resources, sustainable development, and helping people improve their quality of life.

The Robert Bosch Stiftung (Robert Bosch Foundation) was established in 1964 to keep alive the philanthropic and social endeavours of its founder Robert Bosch. Through its programs and institutes, the foundation has since issued 840 million euros in project funds. In 2007, it made available 58.9 million euros for non-profit projects. Education, international understanding, and public welfare are the top priorities stated in Robert Bosch's will and are the pillars of our work today.







Responsibility for the environment is a core value at Bosch and is firmly anchored in our principles for safety and environmental

protection. Our environmental focuses are on renewable energies, energy efficiency, and emissions reduction. At Bosch we believe we have an obligation to develop innovative and beneficial technology and in order to meet such demands, considerable amounts of money are spent each year on research and development. We employ more than 25,000 research and development associates worldwide, all working towards the creation of technology that is innovative, beneficial and environmentally friendly.

© COPYRIGHT 2010 – Robert Bosch (Australia) Pty Ltd

All rights reserved. No part of this publication may be reproduced or transmitted in any form or by any means, electronic or otherwise including, without limitation, photocopying or recording without permission in writing from the copyright owner. All details, illustrations and specifications contained in this publication are based on the latest information available at the time of printing. Whilst every precaution is taken to ensure the accuracy of the content, Robert Bosch (Australia) Pty Ltd accepts no responsibility for any errors or omissions.

Starter Motors & Alternators

Product Information	A2	The Bosch Automotive Story	
	A4	Introduction	
	A6	Starter Motors	
	A8	Alternators - Universal and European	
	A10	Alternators - Australian and Asian	
	A12	Alternators - Liquid Cooled and Refrigeration	
	A14	Alternators - Long Haul	
	A16	Basic Alternator Test Procedure	
	A18	Marketing Materials	
	A19	General Warranty Information	
Application	B1	How to Use This Catalogue	
	B2	Vehicle Applications	
	B505	Refrigeration Applications	
Visual Identification Guide	C2	Alternators - Quick Find Index	
	C4	Alternators - Visual Identification Guide - How to Use	
	C151	Universal Alternators - Visual Identification Guide	
	C162	Alternator Performance Curves	
	C166	Alternator Pulley Configurations	
	C168	Starter Motors - Quick Find Index	
Spare Parts	C170	Starter Motors - Visual Identification Guide - How to Use	
	D2	Spare Parts - Visual Identification Guide	
Cross Reference	E2	Alternators - OE No. to 10 Digit No.	
	E17	Starter Motors - OE No. to 10 Digit No.	

An explanation of the special cases in the applications section (section B) can be found on the inside back cover.



The Bosch Automotive Story



The Bosch Group is a leading global supplier of technology and services, with more than 300 subsidiaries and regional companies in over 50 countries.

The beginnings were humble. In 1898 Robert Bosch developed a magneto ignition device and adapted it to suit a vehicle engine. In doing this he developed the first reliable ignition system, solving one of the greatest technical problems faced by the automotive industry at that time. This key innovation was the first chapter in the success story of Bosch as an automotive supplier.

From 1902 Bosch developed a high voltage magneto ignition system incorporating spark plugs. While the magneto ignition has long since been replaced by battery ignition systems, Bosch today manufactures more than 300 million spark plugs per year, using the very latest precious metal technology.

As cars became a product for the masses, Bosch recognised the prospects for developing motor vehicle lighting. Research in this area resulted in the launch of the Bosch automotive lighting system, comprising of headlights, a generator, a regulator and a battery. This was a significant milestone for both Bosch and the industry, being the first all-in-one system available to consumers, and also the basis for components such as starters, horns, windshield wipers, indicators and car heating systems to be developed and added to the business.

From about 1920, the growth of diesel engines in trucks was a concern at Bosch, because diesel engines did not need an ignition system, the company's main sales driver. To capitalise on this technological advance, Bosch began developing diesel injection pumps and in 1936 launched the first diesel injection pump for passenger cars. Today, Bosch is the global leader in diesel technology, whether it be for passenger cars, trucks or injection systems for ships.

In the years that followed, Bosch made numerous developments with other automotive products. Gasoline injection systems were developed from 1935 and by 1967 had all but displaced the

carburettor. Braking systems have also been part of the Bosch offering since 1927. The introduction of the Bosch ABS antilock braking system in 1978 was a significant development in vehicle safety, laying a foundation for the development of further systems, such as Traction Control and the Electronic Stability Program (ESP®).

In today's market, vehicle manufacturers and service organisations face the worldwide challenge of efficient service for highly evolved vehicle systems. This includes not only mastering the electronic systems in today's automobiles, but also utilising the latest state-of-the-art diagnostics technologies to improve servicing efficiencies. The growing range of Bosch diagnostic and service equipment delivers a sophisticated solution for today's workshops to meet these challenges.

Bosch spends billions of dollars annually in research and development to preserve its position as a technological leader. The company's technological competence is evident in the fact that Bosch is world leader in the number of automotive technology patent applications it submits each year. Every hour Bosch research teams create new patents to make Bosch products safer, more efficient and more environmentally friendly.

As one of the world's largest independent manufacturers of automotive parts and systems, Bosch products and technology, supplied through a global network of factories, can be found on virtually every make of car currently produced throughout the world. This strong link to original equipment development and innovation means Bosch is able to deliver a superior aftermarket offering to its customers.

With most vehicles on the road incorporating many Bosch manufactured components, it made sense for Bosch to support these products with local service centres. The Bosch Service Network is a group of over 14,000 independent workshops worldwide, offering the latest technical expertise, tools and equipment to motorists.



In just over a hundred years, Bosch successfully transformed from a small automotive supplier into a modern, multinational group, which today has a workforce of more than 270,000 people worldwide.

Bosch employs over 2,300 associates in Australia and New Zealand with activities spanning three business sectors: Automotive Technology, Consumer Goods and Building Materials, and Industrial Technology.

During the past five decades Bosch has grown into a major force in the Australian automotive industry. Today, Robert Bosch Australia is no longer a local company manufacturing automotive components only for Australian customers. It is truly an integrated member of the Bosch global network supplying overseas customers in Europe, Asia and America.

In the automotive industry the name Bosch is now synonymous with leading technology, sophisticated service solutions and high quality replacement parts.

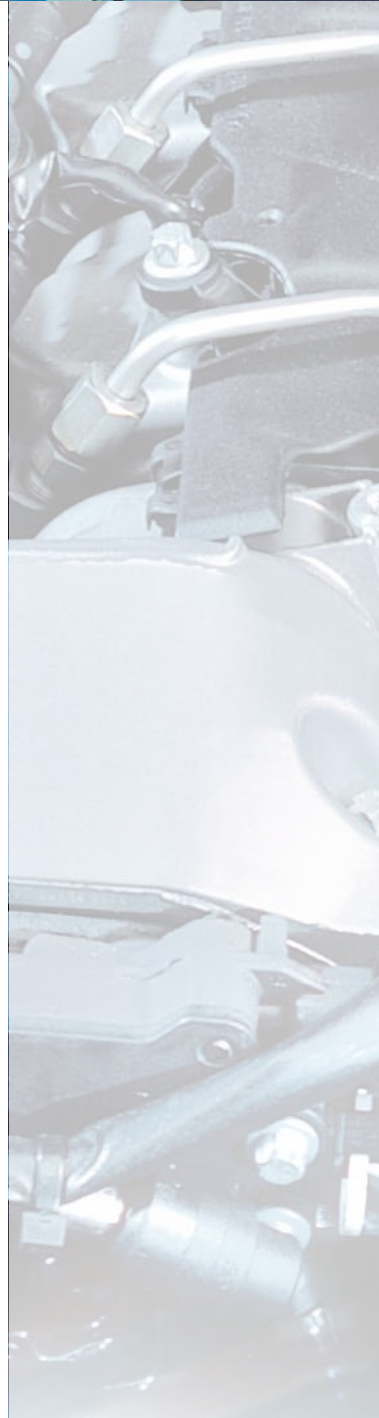

The Expertise of Bosch

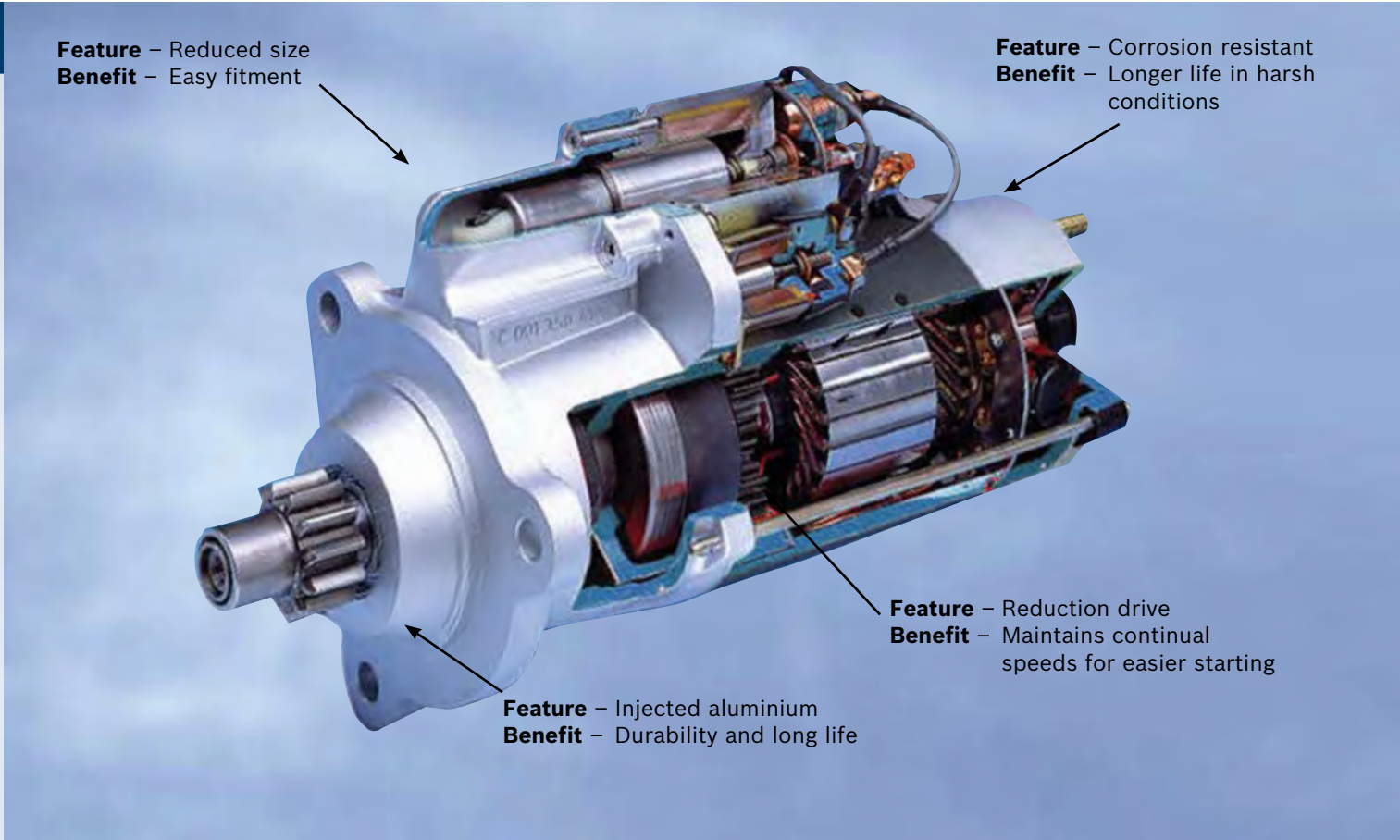

Feature – Reduced size
Benefit – Easy fitment

Feature – Corrosion resistant
Benefit – Longer life in harsh conditions

Feature – Reduction drive
Benefit – Maintains continual speeds for easier starting

Feature – Injected aluminium
Benefit – Durability and long life

Bosch has unparalleled expertise in automotive electrical systems. For over 100 years Bosch has been at the cutting edge of electrical technology and continues to produce market-leading products to the highest quality standards. The commitment to quality is evident in the range of Bosch starter motors and alternators.

Manufactured to Original Equipment Specifications

Bosch starters and alternators are manufactured to Original Equipment Specifications to ensure correct first time fitment and reliable service for years to come.

Suitable for a Wide Range of Applications

Bosch starters and alternators suit a wide range of applications including passenger cars, light and heavy commercial vehicles, construction equipment, agricultural machinery and stationary engines.

Superior Performance

Bosch starters and alternators deliver superior performance, improved fuel economy and longer life.



Feature – Premium quality bearings
Benefit – Long life

Feature – Regulator designed for vehicle application
Benefit – Long life and higher performance

Feature – Non recycled copper
Benefit – Less impurities for greater performance

Feature – High quality raw materials
Benefit – Increased endurance and reliability

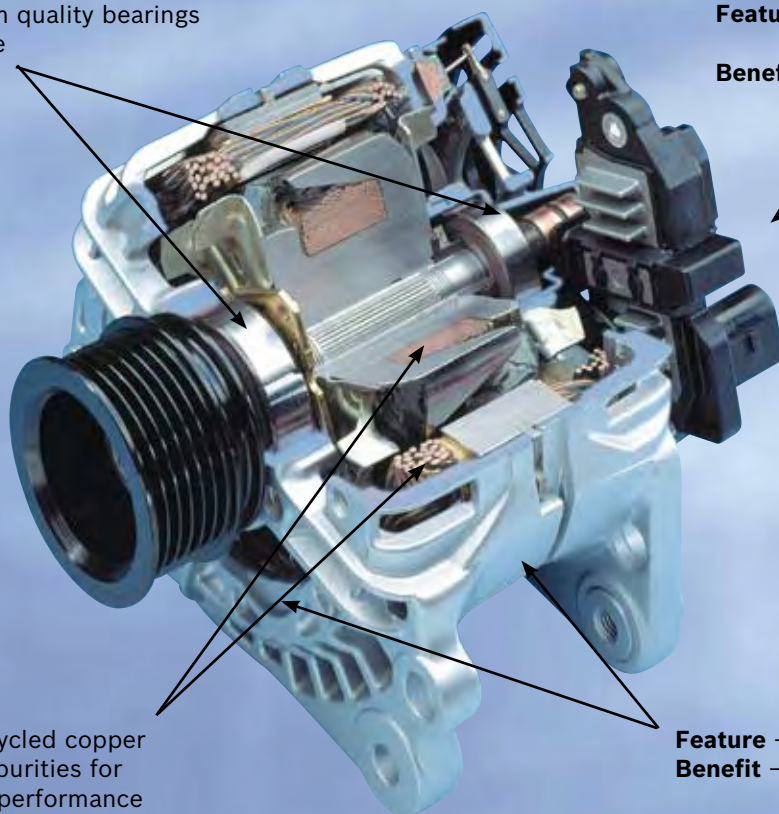

Quality in Every Detail

Cheaper starters and alternators may appear the same, but a closer look will reveal the superior quality and long-term value of Bosch.

High Quality Components

Bosch use the highest quality raw materials in all of their starters and alternators to ensure long life and optimal performance. In the range of starters, this means injected aluminium and corrosion resistant materials. In the alternator range it means premium bearings and non-recycled copper.

A Reputation that Lasts

Bosch starters and alternators represent an investment in quality which will deliver long-term value for both your customer and your business. Why risk increased warranty costs and damage to your workshop's reputation by using inferior products?

Starter Motors



The comprehensive range of Bosch starter motors comprises long-life starter motors for spark-ignition and diesel engines. All Bosch starters meet Original Equipment specifications to ensure long life and high performance.

Greater Efficiency and Power

In order to manufacture compact, high-performance starters, Bosch has reduced the size of the essential starter components and redeveloped them to maintain performance. As a result, Bosch starters are easier to install and, more importantly, offer greater efficiency and power.

Comprehensive Range

Bosch offers a comprehensive range of high quality starter motors for both passenger and commercial vehicles. Whether for gasoline or diesel engines, Bosch starters provide a high degree of reliability and performance coupled with a long working life.

Genuine Bosch Quality

When you purchase a genuine Bosch starter motor you are investing in a quality product with reliable warranty and technical support.

Cutting Edge Start/Stop Technology



Bosch continues to lead the way in starter motor development with Start/Stop technology. Designed in conjunction with some of the world's leading automotive brands, the Bosch Start/Stop System automatically stops the engine when the vehicle is stationary, for example at traffic lights, and restarts it as soon as the driver puts the vehicle back into gear.

The starter motor used in the system has been specifically designed to handle the increased number of starts required, and enhanced meshing mechanics ensure that the engine runs quieter.

Bosch Start/Stop technology improves fuel efficiency and reduces CO_2 emissions, particularly on congested city streets where fuel savings of up to 15 percent can be achieved. With fluctuating fuel costs and stricter emissions regulations, these savings are crucial.

In developing Start/Stop technology, Bosch has once again demonstrated that it is the leader in starter motor development. This leadership is evident across the entire range of starter motors which provide reliable starting year after year.

Universal Range of Alternators



BX Universal alternators suit a variety of automotive applications, particularly Australian, American and English vehicles. Their higher amperage also makes them ideal for agricultural and industrial applications.

Benefits of Bosch Universal alternators:

- ▶ Higher amperage
- ▶ Higher output allows continual operation
- ▶ Suits vehicles with aftermarket options
- ▶ Developed from Original Equipment technology

European Range of Alternators



Only an alternator that is precisely tailored to the vehicle's specific electrical system can maximise efficiency and economy. With unparalleled experience in the development of alternators to suit European applications, Bosch is able to provide this precision and deliver optimum performance for European vehicles. There is simply no better alternative.

Benefits of Bosch European alternators:

- ▶ Manufactured by the European experts from Original Equipment technology
- ▶ Manufactured using only premium-quality windings and bearings
- ▶ All units are full-load tested to guarantee compliance with Bosch's strict performance specifications
- ▶ All units comply with the highest demands for power output and efficiency
- ▶ Covers a wide range of European applications

Australian Range of Alternators

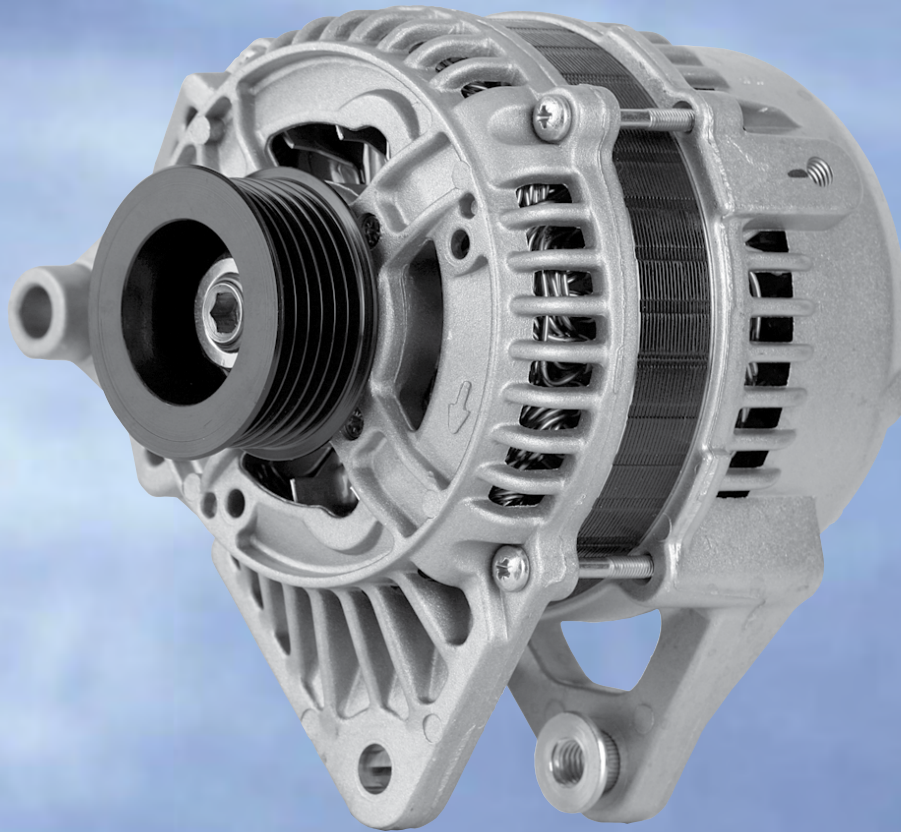

Australian built vehicles continue to be some of the most popular on our roads. They owe their popularity to the fact that they are built for the unique driving conditions of Australia which include extreme temperatures and long distances. The Bosch BX Australian range provides quality alternators to suit this range of vehicles.

Benefits of Bosch Australian alternators:

- ▶ Designed to withstand extreme Australian temperatures
- ▶ Manufactured using only premium-quality windings, and bearings
- ▶ All units are full-load tested to guarantee compliance with Bosch's strict performance specifications
- ▶ All units meet Original Equipment specifications

Asian Range of Alternators



Asian vehicles are becoming increasingly popular on our roads. These vehicles are characterized by high efficiency and performance and require a compact alternator that still delivers high output and high capacity. The Asian range of Bosch alternators provides these performance characteristics, making them ideally suited to the most popular Asian imports.

Benefits of Bosch Asian alternators:

- ▶ Compact, low-noise alternators, designed specifically for Asian applications
- ▶ Manufactured using only premium-quality windings, and bearings
- ▶ All units are full-load tested to guarantee compliance with Bosch's strict performance specifications
- ▶ All units comply with the highest demands for power output and efficiency
- ▶ All units meet Original Equipment specifications

Liquid Cooled Alternators



Modern prestige vehicles include a high number of electrical components which place enormous strain on the alternator. Bosch liquid cooled alternators are designed specifically to handle the high electrical loads of these vehicles.

Liquid cooled alternators use coolant from the engine's cooling system which passes through a water jacket in the alternator, keeping the body and its electronics operating at a stable heat range. By using liquid rather than a fan, these alternators also offer the advantages of whisper quiet operation and reduced load on the engine.

Benefits of Bosch Liquid Cooled alternators:

- ▶ Direct replacement for Original Equipment
- ▶ Liquid cooled technology provides whisper quiet operation
- ▶ Designed to handle the higher electrical loads of prestige vehicles
- ▶ All units are full-load tested to guarantee compliance with Bosch's strict performance specifications

Refrigeration Alternators



Bosch has developed three alternators specifically for refrigeration trucks equipped with dual-temperature refrigeration units. These units feature heavy duty, high tolerance bearings, anti-corrosion coatings, a sealed brush box, a Zener diode rectifier plate and single mounting foot for increased service life.

Benefits of Bosch Refrigeration alternators:

- ▶ Original Equipment quality
- ▶ Designed to suit the high demands of refrigerated transport industry
- ▶ Built to fit application, no modification necessary
- ▶ Produces higher output at lower engine speeds
- ▶ Can be used in conjunction with battery sentinel units

Bosch Heavy Duty Output Alternators



Bosch Long Haul alternators feature high efficiency alternator technology which delivers maximum charging power over the long-haul. With 160/200 Amps on-the-road output and 80/120 Amps at idle, these alternators provide superior output under all operating conditions.

Longer Battery Life

Bosch Long Haul alternators represent the next generation of heavy vehicle charging technology, delivering more power and greater efficiency than competitive alternators. Bosch's higher charge rate at idle helps maximise battery life by reducing battery cycling.

High Temperature Resistance

Several features allow Bosch units to withstand operating temperatures up to 13% higher than competitive units. The amount of cooling air being pulled through the unit is maximised by dual internal cooling fans which draw air from both the front and the rear of the alternator forcing heat out through the vents circling the housing. The units also feature long life bearing technology which combines special heat-treated, long life steel bearings with heat resistant lubricant to better withstand heat and wear.

At an operating temperature of 80°C, Bosch Long Haul alternators sustain superior operating amperage to supply more power for critical electrical systems.



Exclusive Self Protection Technology

Amperage output is automatically reduced when under hood temperatures exceed 125°C, allowing the alternator to continue to provide necessary power while protecting internal components. Output returns to normal levels when the temperature drops below 125°C. Cooling is also provided by an external heat dissipating rectifier which is mounted in the cool-air intake stream.

Greater Efficiency and Lower Fuel Consumption

High efficiency winding technology, using 30% more copper than other units, increases efficiency and lowers fuel consumption. Heavy duty slip ring technology is also used to significantly reduce wear on the brushes.

Fewer Part Numbers for Reduced Inventory

With only four part numbers replacing over 200 Original Equipment part numbers, inventory commitment can be greatly reduced.

Benefits of Bosch Long Haul alternators:

- ▶ Higher charge rate at idle for longer battery life
- ▶ Built to withstand higher operating temperatures
- ▶ Self Protection Technology protects internal components in extreme temperatures
- ▶ 30% more copper provides increased efficiency and lower fuel consumption
- ▶ Reduced inventory with four part numbers replacing over 200 original equipment part numbers
- ▶ Direct replacement for Delco, Prestolite and Leece Neville units

Basic Alternator Test Procedure

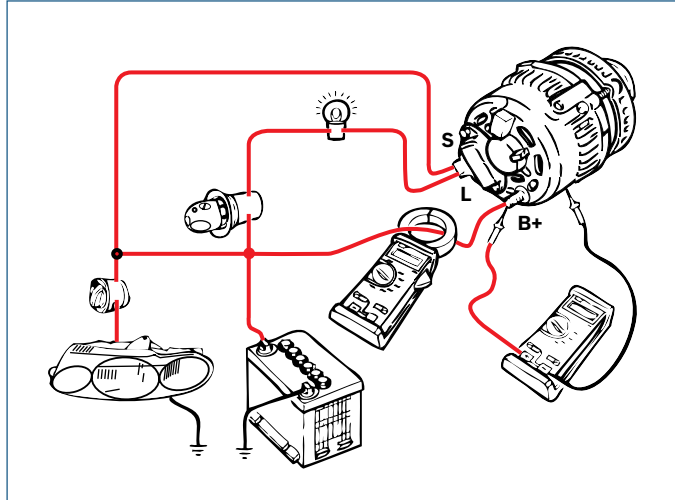
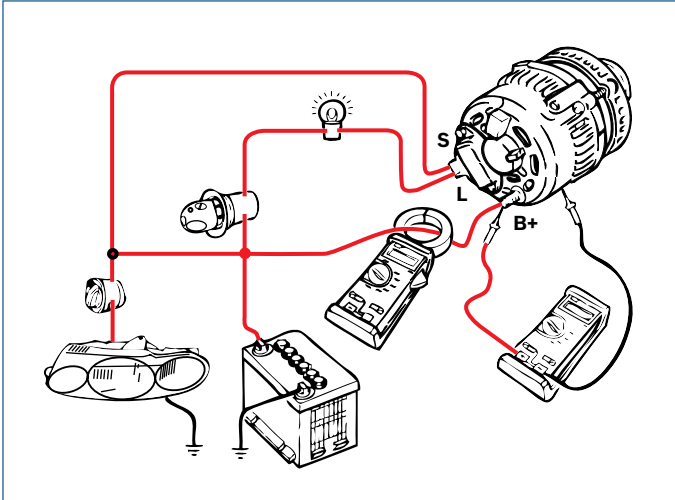

Regulator Voltage Test

Output Voltage Test

1. Connect a voltmeter (0 – 20 volt) between the alternator B+ terminal and the alternator case (from ground connection).
2. Connect an ammeter (refer Notes below) in series with the alternator B+ battery cable.
3. Start the engine and increase engine speed to 2000 RPM.
4. Switch on or off headlights, etc. to adjust the current load to show on the ammeter to between 5 and 10 amps.
5. Observe the voltage reading and record:
 - ▶ If 13.8 to 14.5 volts. Test passed.
 - ▶ If not 13.8 to 14.5 volts. Test failed.

Notes:

- A. With an inductive pick-up type ammeter (150 A capacity) i.e. TECH 31 - PMS 100 or similar.
- B. With a standard ammeter (150 A capacity) by disconnecting the battery lead from the B+ alternator terminal and inserting the ammeter in series in the correct polarity.

Output Current Test

Output Voltage Test

1. Record alternator Output Code stamped on the alternator casing:
 - Example – 14V 17/85A. This is 17 amps at alternator speed of 1800 rpm and 85 amps at 6000 rpm.
2. Connect a voltmeter (0 – 20 volt) between the alternator B+ terminal and the alternator case (from ground connection).
3. Connect an ammeter (refer Notes below) in series with the alternator B+ battery cable.
4. Start the engine and increase engine speed to 2500 RPM. (approx. 6000 RPM alternator speed).
5. Load the alternator by switching the headlights, etc. on to achieve a voltmeter reading of 13.5 volts.
6. Observe the ammeter reading and record:
 - ▶ If maximum alternator output current is achieved (as per 6000 alternator rpm related Output Code) test passed.
 - ▶ If Output Code specification not achieved, test failed.

Notes:

- A. With an inductive pick-up type ammeter (150 A capacity) i.e. TECH 31 - PMS 100 or similar.
- B. With a standard ammeter (150 A capacity) by disconnecting the battery lead from the B+ alternator terminal and inserting the ammeter in series in the correct polarity.

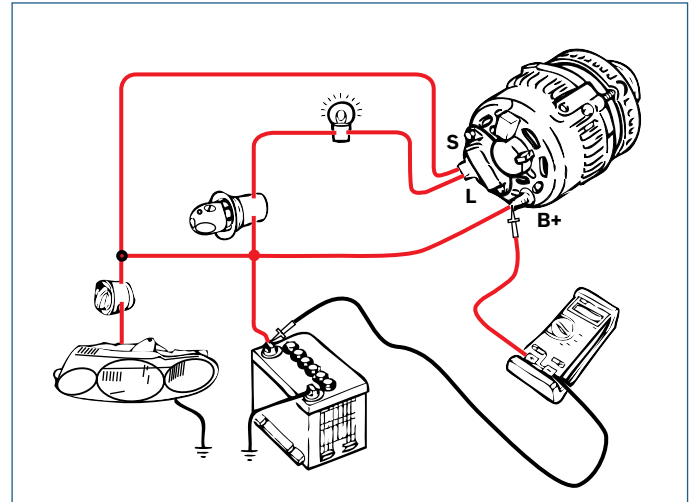
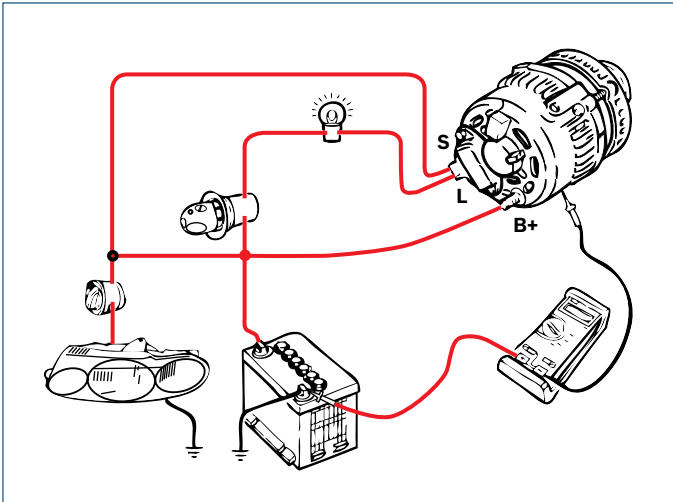

Earth Circuit Voltage Drop Test

Output Voltage Test

1. Connect a voltmeter (select the 1.0 volt scale) between the alternator case (ground) and the negative (-) battery post (not the clamp).
2. Start the engine and increase engine speed to 2000 RPM.
3. Switch on the headlights, etc. to load the alternator to achieve a voltmeter reading of 13.5 volts.
4. Observe the voltage reading and record:
 - ▶ If less than 0.30 volt. Circuit is OK.
 - ▶ If greater than 0.30 volt. Circuit has excessive resistance (check connections, etc.).

Charge Line Voltage Drop Test

Output Voltage Test

1. Connect a voltmeter (select the 1.0 volt scale) between the alternator B+ terminal and the positive (+) battery post (not the clamp).
2. Start the engine and increase engine speed to 2500 RPM.
3. Switch on the headlights, etc. to load the alternator to achieve a voltmeter reading (between the B+ and earth) of 13.5 volts.
4. Observe the voltage reading and record:
 - ▶ If less than 0.30 volt. Circuit is OK.
 - ▶ If greater than 0.30 volt. Circuit has excessive resistance (check connections, etc.).

Marketing Materials



The following marketing materials are available to complement this catalogue. To obtain copies, please contact your Bosch distributor.



Liquid Cooled Alternator Brochure

4 page brochure listing applications for the range of Liquid Cooled Alternators

Long Haul Alternator Brochure

6 page brochure highlighting the performance features of the Long Haul Range

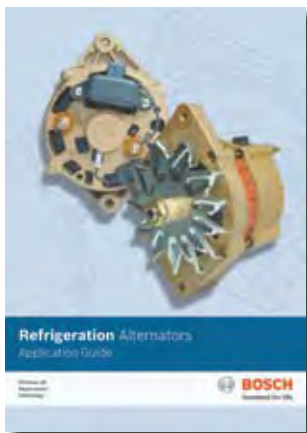

Refrigeration Alternator Application Guide

8 page brochure providing technical information and applications listings for refrigeration alternators

Visual Identification Posters

5 posters providing pictures and part numbers of fast moving products within our Australian, European, Asian, Commercial and Spare Parts ranges.



BX Poster Pack

1 x A1 Vehicle application chart;
4 x A2 Alternator series posters



Robert Bosch Australia

General Warranty Information

Introduction

All products manufactured and/or sold by Bosch Australia carry a statutory and voluntary warranty. Consumer's rights to such warranty are limited to failures and defects caused by a material or manufacturing fault within the specified warranty period.

This warranty information describes very broadly the general procedure for the settlement of warranty claims. Detailed information relating to the most commonly submitted non-warranty cases should also be reviewed prior to any warranty submission. Only genuine warranty cases are accepted.

What is a Warranty Case?

A warranty case exists when a Bosch product or spare part fails within the specified warranty period as a result of a manufacturing or material fault.

What are Non-warranty Cases?

A warranty case does not exist if the fault is caused by a violation of the operating, maintenance or installation instructions, inappropriate or improper use, incorrect handling or unauthorised repairs and modifications performed by third parties. Other examples of non-warranty cases are failures caused by foreign contamination and water entry.

Natural Wear and Tear

Damage caused by natural wear and tear does not constitute a warranty case even if it occurs within the warranty period.

Wrong Deliveries and Transit Damage

Wrong deliveries, incorrect or damaged packing and transit damage claims are not warranty cases and will not be processed as a warranty claim. Such cases should be directed to Bosch Customer Service on 1300 30 70 40.

Warranty Responsibility and Evaluation

All warranty claims are to be resolved in the most economical and efficient way, either by repair or replacement. In the case of Bosch starter motors and alternators, these must be sent to a Bosch Authorised Service Dealer for warranty evaluation and/or repair.

For details of your nearest Bosch Authorised Service Dealer please call our hotline on 1300 060 060 or visit www.bosch.com.au

Initiating a Claim

If a Bosch product fails within the specified warranty period as a result of a manufacturing or material fault, consumers should:

- ▶ Stop using the goods
- ▶ Let the seller know as soon as possible
- ▶ Look after the goods until they are returned
- ▶ Return the goods, including proof of purchase (while there are no time limits, this should be done as soon as possible).

Packaging

Goods do not have to be returned with the original packaging to obtain a refund.

Warranty Periods and Proof of Purchase

The warranty period begins from the date of sale to the customer (generally the consumer). The warranty period is not renewed nor extended as a result of a warranty repair or with the supply of a replacement part. The seller is entitled to ask for proof of purchase when goods are claimed under warranty and consumers are obligated to provide proof of purchase when claiming goods under warranty. Proof of purchase will generally indicate if the purchased product is covered under warranty.

The warranty period for Bosch starter motors and alternators is as follows:

Passenger vehicle applications – 24 months/40,000km
Commercial vehicle applications – 12 months/20,000km

Deadlines for submitting Warranty Claims

Bosch Australia aims to rectify genuine quality problems as a priority. This is generally achieved by investigating why defective products have failed and by introducing immediate corrective action measures to prevent re-occurring warranty failures. It is therefore critical that all warranty cases are promptly reported to Bosch Australia. Bosch reserves the right to request the prompt return of all defective parts.

Product Liability and Product Safety

Bosch Australia should be informed immediately about potential product safety concerns within and outside the warranty period. Bosch Australia is well aware of its product liability and product safety obligations and responsibilities. It is our aim to ensure appropriate product safety standards are met in order to avoid injury, loss and damage caused by defects in Bosch products.

