

Gas Instantaneous Water Heaters



For your safety

If you smell gas:

1. Close gas isolating cock
2. Open windows
3. Do not actuate any electrical switches
4. Extinguish naked flames
5. Contact gas authorities immediately

Do not store or use flammable materials or liquids near the appliance.

Do not place articles on or against this appliance.

Approved for indoor installation only.

WR 250 -8 K..G..

WR 325 -8 K..G..

WR 400 -8 K..G..

with Hydropower Ignition

- THE APPLIANCE MAY ONLY BE INSTALLED BY AN AUTHORISED PERSON.
- Perfect functioning of the appliance is guaranteed only if this specification and the operating instructions are followed.
- The customer shall be provided with these installation instructions.
- The fitter shall explain the function and operation of the appliance to the customer.
- Servicing may only be carried out by authorised personnel.
- Installation in a marine environment should be avoided.
- Install in accordance with AS5601, AS/NZS3500.4.2, NZS5261 and all local building, water and gas fitting regulations.
- Not suitable for pool or SPA application.
- Failure to install the appliance in accordance with these installation instructions may void warranty.

Index

	Page		Page
1. Description of Appliances	2	3.5 Water Supply	5
1.1 Equipment	2	3.6 Gas Connection	5
1.2 Type Overview	2	3.7 Flue	5
1.3 Connecting Measurements	3	3.8 Commissioning	5
1.4 Constructional Details	3	3.9 HDG Functioning	5
1.5 Wiring Diagram	4		
2. Technical Data	4	4. Servicing	5
3. Installation	5	4.1 Setting Appliance	5
3.1 General Remarks	5	4.2 Gas adjustments	5
3.2 Location	5	4.3 Conversion to Other Gases	6
3.3 Connecting Appliance	5	4.4 Maintenance	6
3.4 Removal of Front Shell	5	4.5 Fault Finding	7
		5. Operating Guide - Quick Reference	8

1. Description of Appliances

Multipoint gas water heaters with hydropower ignition and built-in draught diverters for flued connection.

White plastic-coated front casing.

Automatic gas adaption by means of continuous gas control.

Suitable for small and large hot water consumption.

1.1 Equipment

- fully protected with sensor electrode flame failure device;
- hydropower ignition;
- automatic power adaption;
- temperature limiter in power circuit;
- draught diverter.

1.2 Type Overview

W	R	250 - 8	K	V	1	G	²³ ₃₂	S 2405
W	R	325 - 8	K	V	1	G	²³ ₃₂	S 2405
W	R	400 - 8	K	V	1	G	²³ ₃₂	S 2405

W	Multipoint gas water heater
R	Automatic power adaption
250	Code number 17,5 kW (250 kcal/min)
325	Code number 22,75 kW (325 kcal/min)
400	Code number 28 kW (400 kcal/min)
-8	Version code number
K	Chimney flue
V	Connector
1	Temperature selector
G	Hydropower ignition
23	Gas code number, natural gas H
32	Gas code number, LP gas
S2405	Australian Execution

1.3 Connecting Measurements

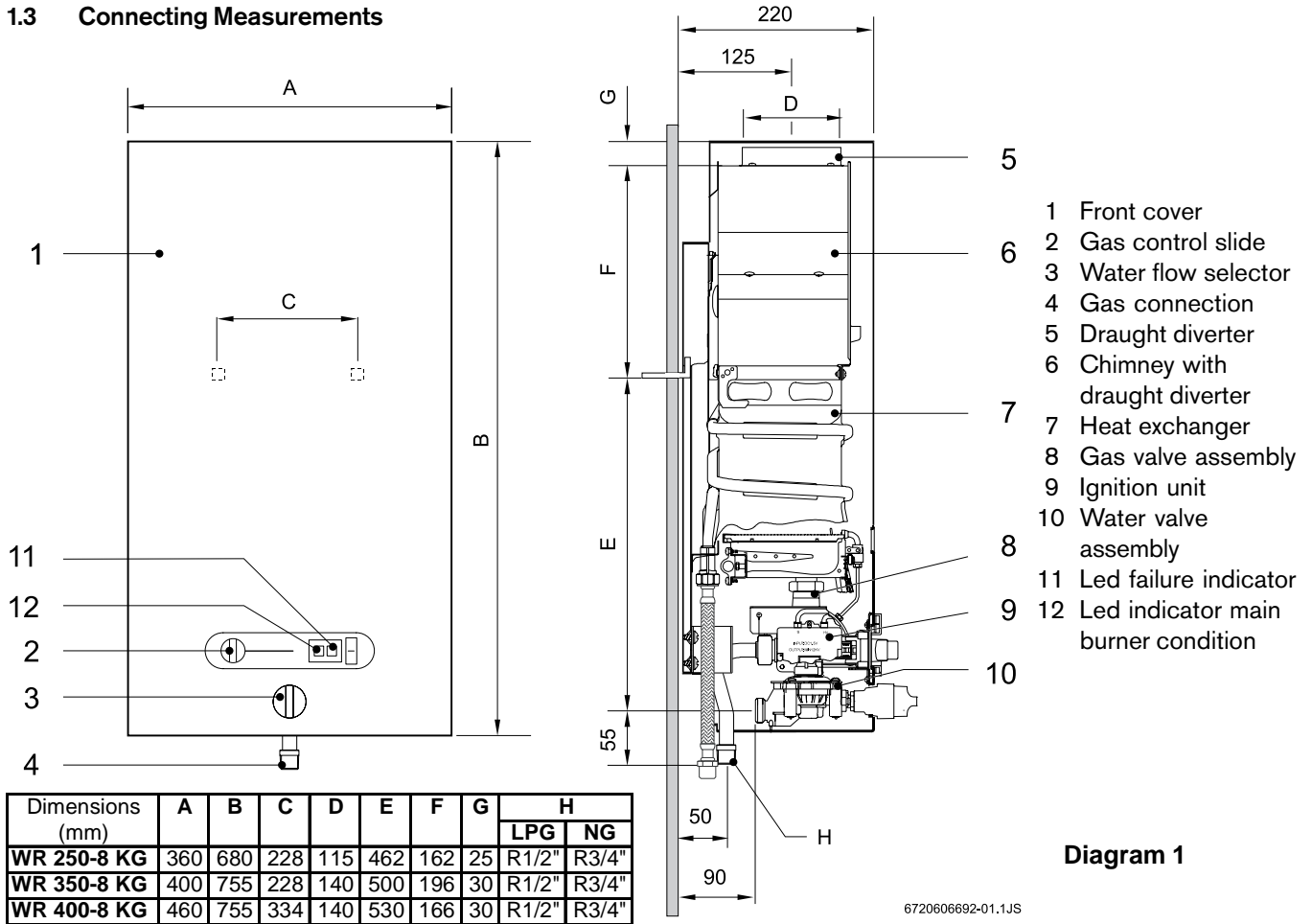

Diagram 1

6720606692-01.1JS

1.4 Constructional Details

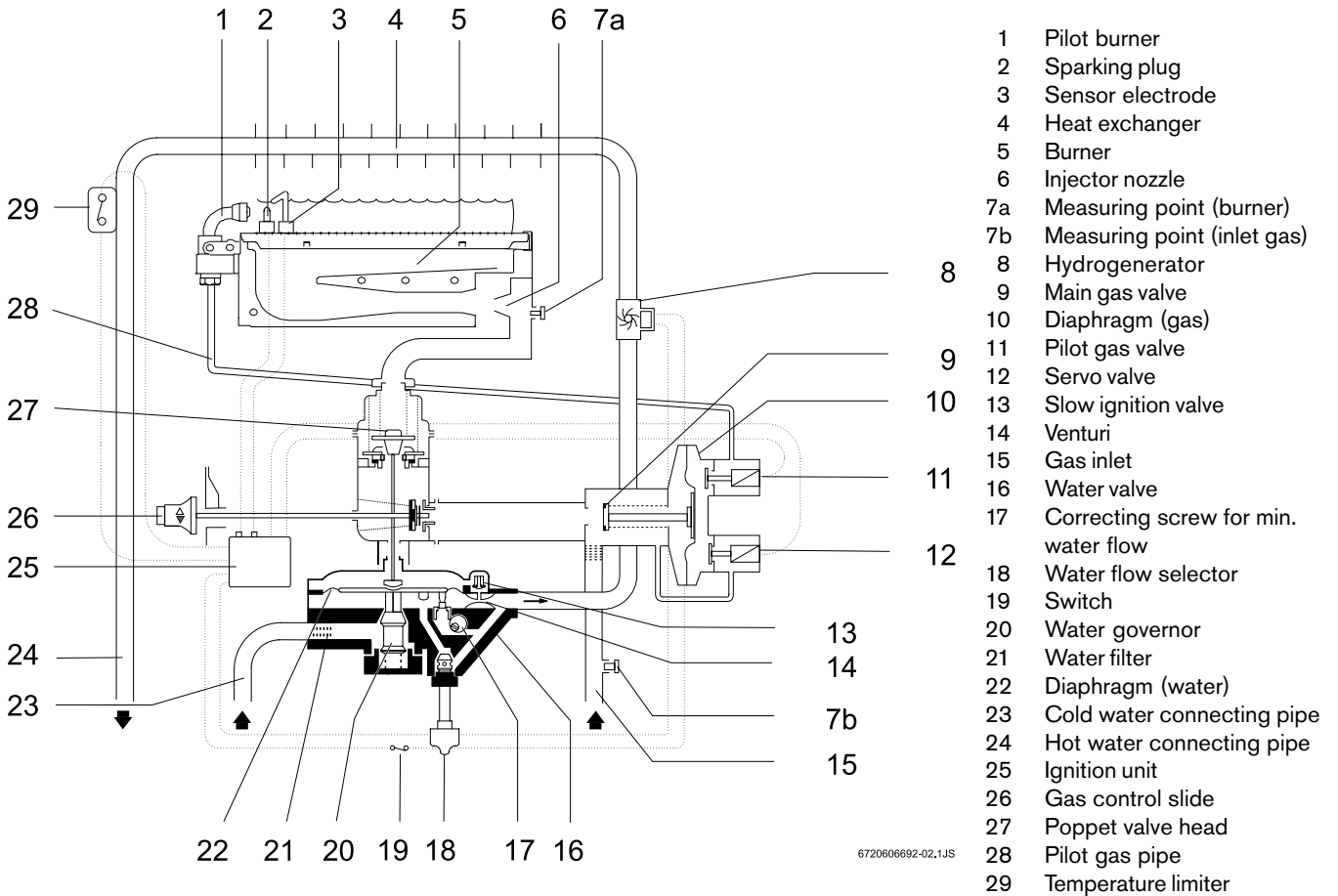

Diagram 2

6720606692-02.1JS

3. Installation

Install in accordance with AS5601, AS/NZS3500.4.2, NZS5261 and all local building, water and gas fitting regulations.

3.1 General Remarks

Any local by-laws and regulations pertaining to installation and use of gas-heated appliances must be observed.

3.2 Location

The appliance should be installed in a frost-protected, well ventilated room, as near as possible to the most frequently used tap. In order to prevent corrosion, make sure that the combustion air is kept free of aggressive substances. Substances that especially contribute to corrosion are halogenated hydrocarbons (e.g chlorine, fluorine), which are contained in solvents, paint, adhesives, propellant gases, various household cleaners, etc.

Cupboard-like Enclosures

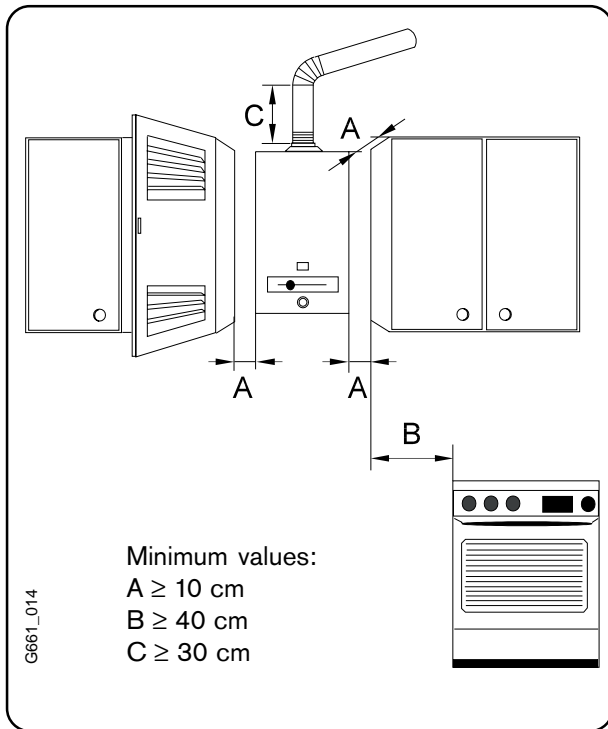

Diagram 4

Note: Ventilation requirements as per AS5601.

3.3 Connecting Appliance

Secure heater to the wall using the two mounting brackets supplied.

3.4 Removal of Front Shell

Remove retaining nut (below gas slide). Swing the casing to the front and push upwards.

3.5 Water Supply

Pipes of suitable bore according to local conditions and in

compliance with pertinent regulations to be used. Cold water inlet (right) and hot water outlet (left) are marked by arrows on the water valve housing. Use only Gate Valve or Full Flow Ball Valve. Non-Return Valves MUST NOT BE USED.

Cold water - flush all lines prior to connection. Make sure water filter is fitted to inlet point of water valve. Fit inline water strainer where appropriate.

3.6 Gas connection

Size gas supply pipe as per AS5601. Note: inadequate pipe sizing may void the warranty.

3.7 Flue

Use approved single or twin skin flue in accordance with AS5601.

3.8 Commissioning

Purge gas piping of air. Trapped air can result in the pilot burner failing to light within 30-40 seconds. In that case, turn off the hot water tap and then turn it on again. This restarts the ignition cycle.

3.9 HDG Functioning

HDG is located in the water circuit, between the water valve and the heat exchanger. The HDG has a turbine, which turns with the water flow. This movement is transmitted to an electric generator, which supplies the electronic box. The electric voltage supplied by the HDG is a value between 1,1 and 1,7 V DC. With the HDG, the use of batteries is no longer necessary.

4. Servicing

4.1 Setting Appliance

All heaters are adjusted before leaving the factory. LPG gas heaters are adjusted for 2,75 kPa and Natural gas heaters for 1,11 kPa.

Note: Make sure that the appliance is suitable for the type of gas available at the installation.

4.2 Gas adjustments

Gas burner pressure adjustment for maximum output

1. Turn off gas supply.
2. Loosen sealing screw D (diagram 5) and connect U tube manometer.
3. Turn on gas supply and start up appliance in accordance with operating instructions. Fully open a hot water tap.
4. Check that burner pressure is as stated on the rating label.
5. If other than specified test inlet pressure. Turn off gas supply, remove manometer, tighten sealing screw, turn on gas supply and test for leaks.

Gas burner pressure adjustment for minimum output (see clause 4.3, section 8)

Gas inlet pressure adjustment

1. Turn off gas supply.
2. Remove inlet test point screw A.
3. Attach U tube manometer.
4. Turn on gas supply and start up appliance in accordance with operating instructions.
5. Check inlet gas pressure while appliance is operating.
6. For natural gas appliances adjust pressure at appliance regulator.
No adjustment for LP appliances, check cylinder regulator and pipe size.
7. Turn off gas supply, remove manometer, replace sealing screw, turn on gas supply and test for leaks.

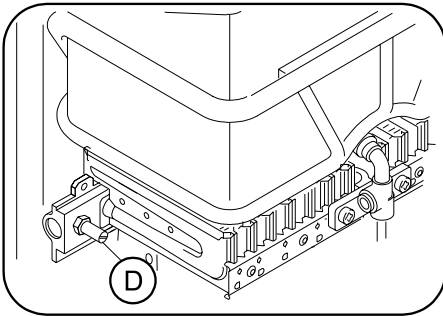

Diagram 5

4.3 Conversion to Other Gases

Only use conversion kits supplied by the manufacturer.

This operation must be carried out by a qualified fitter.

1. Cut off the gas supply by closing the gas isolating valve, and remove the front cover of the appliance;
2. Remove the burner and replace the injectors (diagram 7, item 1);
3. Replace the pilot gas injector (diag. 7, item 3);
4. Replace the vacuum chamber if converting from LP to NG. Pressure regulator also required.
5. Replace the main poppet valve head (diag.2, item 27);
6. Tighten the gas valve and check for possible leaks;
7. Note the new type of gas on the appliance's rating plate;
8. Finally, adjust the minimum gas flow of the appliance using a suitable method, the most common one being described below:
 - a) Select a manometer with a mbar or mm (H₂O) scale;
 - b) Loosen sealing screw D in the burner pressure tap-off point (diagram 5) and connect the manometer;
 - c) Open the gas isolating valve;
 - d) Start up the appliance with the output slide control at the minimum output position;
 - e) Adjust the pressure using screw C (diagram 6), in compliance with Section 2 Technical Data, page 4.

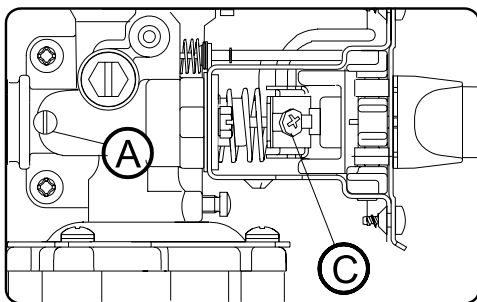

Diagram 6

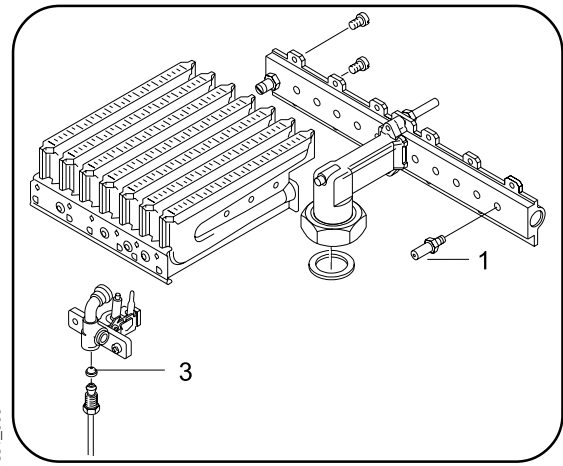

Diagram 7

4.4 Maintenance

When it has been in service for a year, the appliance should be inspected, thoroughly cleaned and, if necessary, descaled.

Servicing may only be carried out by an authorised person. Before carrying out maintenance work of any kind, the gas and cold water isolating cocks must be turned off.

Heat Exchanger body

Clean the flue side of the heat exchanger block. Check heat exchanger body and connecting pipes for scale and if necessary descale with proprietary descaler according to manufacturers instructions.

The descaling is done only to the heat exchanger, the chemicals used damage the HDG and other parts.

Test for leaks at max. 2000 kPa.

Use new gasket when re-assembling.

Burner

Unscrew burner and clean in soap solution if necessary.

Pilot burner

The flame should heat the flame-failure electrode (diagram 3, item 4). If the flame is too small, clean pilot burner.

Slow ignition valve

After unscrewing the valve, clean out any dirty particles. The ball inside the valve must move freely (check by shaking). Inspect the O-ring and replace if necessary. Screw the slow ignition valve back in. Check all connections for leaks.

Checking the vacuum chamber

- Push the sliding gas control to the right and draw off hot water.
- Disconnect green lead from the servo gas valve (diagram 3, item 1). The main burner should go out and the pilot burner remains lit. Disconnect the red lead from the pilot gas valve (diagram 3, item 3) - the pilot flame should then go out.
- Re-connect red lead, pilot burner should re-ignite.
- Re-connect green lead, main burner should re-ignite.

Functional Test (does not apply to first time commissioning).

Switch off appliance. When a hot water tap is turned on, the burner should come on full within 5 seconds. When the hot water tap is turned off, the burner should go out within approximately 2 seconds.

Re-commissioning after repairs to the gas supply

Purge gas piping of air. Trapped air can result in the pilot burner failing to light within 30-40 seconds. In that case, turn off the hot water tap and then turn it on again. This restarts the ignition cycle.

Frost Protection

In areas where the atmospheric temperature drops below 0°C, the heater must be drained to prevent damage due to the expansion of freezing water.

4.5 Fault Finding

The following table outlines some common problems and their solutions.

Problem	Cause	Solution
Appliance does not light.	Switch in "off" position. Pilot solenoid. Over temperature switch. No power to pilot solenoid.	Put it in the "on" position. Replace solenoid. Replace switch. Replace ICU.
Pilot lights but no main burner.	Slide control set to off. Main solenoid open circuit.	Turn control to on. Replace solenoid.
Smell of gas.	Luminous flame. Loose gas connection.	Clean burner. Locate leak with soap solution.
Yellow flame.	Burner venturi blocked.	Clean with venturi brush.
Water leak on top of water valve lid.	Damaged O ring. Excessive pressure. Frost damage.	Replace O ring, grease with Unisilikon L641# 8709918413. Check water isolating valve. (Must be gate valve or similar). Drain appliance or fit Exogel expansion valve # H707060151.
No variation in water flow rate.	Damaged selector shaft. Excessive water pressure.	Replace shaft. Check water supply pressure.
Low burner flame, water does not heat up.	Low inlet gas pressure. Low burner pressure. Low water flow. Low flame.	Check supply regulator and pipe size. L.P.G. appliances - Check if gas container freezes while in use. If so, place it in a warmer location. Check appliance regulator. Check water flow rate. Move slide control to high.
Low water temperature.	Water flow selector set in warm position. Low gas pressure. Cross connection.	Set flow rate to individual need. Check pressure. Disconnect hot outlet with cold off. Correct connection.
Low water flow.	Low water pressure. Blocked water valve. Blocked heat exchanger. Blocked shower rose or tap aerator.	Check and adjust. Clean filter. Descale. Clean.
Slow Ignition spark.	Faulty over temperature switch.	Replace switch.
No spark.	Faulty ICU. Faulty flame sensing rod.	Replace ICU. Replace flame sensing rod.
Pilot burner hard to ignite.	Insufficient water pressure.	Check and adjust.
Red led flashing.		
Main burners go out during hot water use.	Temperature limiter activated.	Re-ignite the appliance 10 minutes later. If it happens again, contact your service person.

5. Operating Guide - Quick Reference

**Purge all water and gas pipes before operating.
Turn off all water taps before adjusting appliance.**

Starting and shutting off the appliance

To switch the appliance, turn the on/off switch to position "1"

To shut off the appliance, turn the on/off switch to position "0"

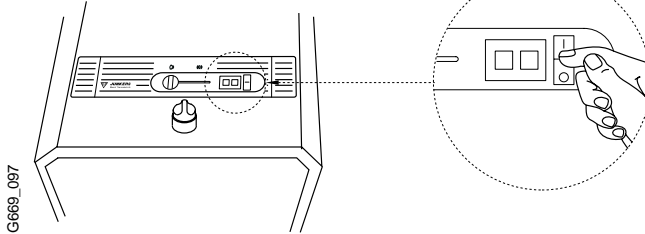

Green light on= Main burner on
Green light off= Main burner off

Red light flashing:
check water pressure

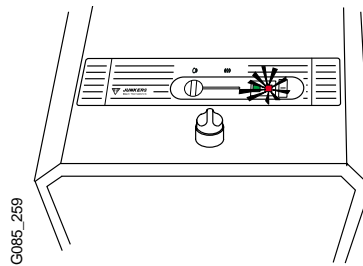
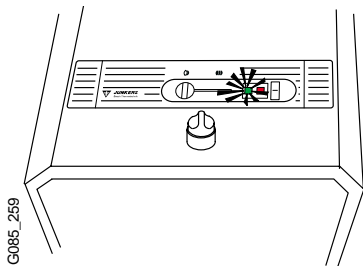

Output control

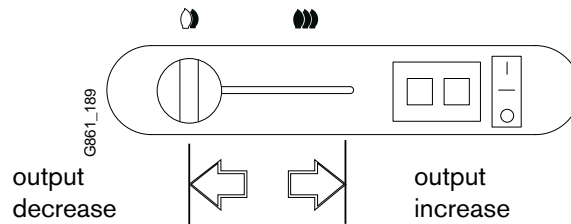

Temperature regulation

Turn anti-clockwise

Water flow increases,
temperature diminishes

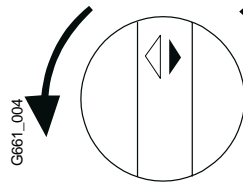

Turn clockwise

Water flow decreases,
temperature increases.

Warning - If the appliance does not operate, burns with yellow flame, leaks water or a gas smell is evident, turn off and contact the local gas authority, the manufacturer or an authorised service person.
When attempting to light the appliance ensure that all hot water taps are turned off.

Warranty Details

Your Bosch Hot Water Unit is guaranteed as follows:

For appliances used in domestic applications, ie. normal hot water drawn from household outlets, the warranty period is One (1) years parts and labour. Additionally, the heat exchanger is covered for a period of ten (10) years (parts only).

For appliances used in commercial applications the warranty period is Six (6) months parts and labour including the heat exchanger.

The warranty period commences from the purchase date. Claims for warranty will only be accepted upon suitable proof of purchase submitted to Robert Bosch (Australia) Pty. Ltd. or an approved Bosch Service Agent authorised to carry out warranty repairs.

PURCHASER'S STATUTORY RIGHTS

The warranty terms set out below do not exclude any conditions or warranties which may be mandatory implied by law, and your attention is drawn to the provisions of the Trade Practices Act, 1974, and State legislation which confers certain rights upon consumers. The ROBERT BOSCH (AUSTRALIA) PTY. LTD. Warranty supplements these.

EXTRACT OF TERMS OF DELIVERY AND SALE:

Warranty of products marketed by Robert Bosch (Australia) Pty. Ltd. herein referred to as RBAU.

- a) RBAU warrants products marketed by it as free from faults and defects and having the specified qualities according to the respective state of technology. Notwithstanding that the products may have been sold by description or sample the products shall be accepted by the Buyer even though alterations in design or construction have been generally introduced between the date of contract and the delivery of the products.
- b) The warranty shall be limited to the replacement or repair at the option of RBAU of any defective products and of such parts of RBAU's products as have been damaged in consequence of the defect despite proper treatment. Parts replaced will not be returned.
- c) i) Repairs and maintenance shall not extend the warranty period of the appliance.
ii) If the product is located outside of the service agent's area, the consumer shall be responsible for the service agent's travelling costs, and if necessary the expenses of freight, packing and charges of a similar nature.

Without limiting the generality of these terms of delivery this warranty shall not apply to products sold in the following cases :--

- i) if the products sold are repaired or altered by any third party without RBAU's consent.
- ii) where parts not manufactured or sold by RBAU are used in and replacement or repair.
- iii) if products are not used with proper care and for the purpose for which they are sold and in accordance with any specified instruction for use.
- iv) if changes occur in the condition or operational qualities of the products due to incorrect storage or mounting or due to climatic or other influences.
- v) in respect of faulty construction or defects due to the use of unsuitable materials if such method of construction or use of material has been specified by the Buyer.
- vi) in respect of surface coating and glass damage.
- vii) in respect of the replacement of parts when such replacements are part of the normal maintenance, service or normal wear and tear.

No servant or authorised service agent has authority to add to or alter the terms of this warranty.

PLEASE NOTE:- If a service call is requested and it is found that it is not a manufacturing fault, you may be charged for the call even during the warranty period.

ROBERT BOSCH (AUSTRALIA) PTY LTD
(Incorporated in Victoria) Phone 1300 30 70 37

Melbourne
57-63 McNaughton Road Clayton
Victoria 3168
Phone (03) 9541 5555
Fax (03) 9541 5595

New Zealand
14-16 Constellation Drive,
Mairangi Bay,
Auckland 1310

Sales Hotline 0800 4 26724

Sales Hot line: 1300 30 70 37
Sales Fax: 1300 30 70 38

www.bosch.com.au